

<b>Scheme Name</b>	<b>Traffic Calming and Extension of 20mph zone on the High Street, Berkhamsted</b>	
	Highways and Congestion	
<b>Scheme Reference</b>	05	
<b>Problem References</b>	B11	Not enough cycle facilities, current facilities are poor quality
	B15	High Street traffic calmed but remains traffic dominated
	B18	Little cycle specific provision throughout the town
	B07	Widening of London Rd for cycle lane has created speeding and dangerous conditions
<b>Links to other UTP schemes:</b>	01, 08, 10, 14, 15, 19, 20, 26	

**Context**



*Location Plan*

Berkhamsted town centre is a busy shopping area, characterised by multi-use functions. Traffic regularly queues through the town centre from the Kings Road / High Street Junction; there is high demand for parking and loading, and bus stops are located at key points along the link. The town centre is within Berkhamsted Conservation Area and all proposals will therefore need to be sensitive to the requirements of Dacorum Borough Council in this regard.

The High Street is the most direct route through the town centre for cyclists, and its position on the valley floor means it does not have the steep inclines common throughout much of

Berkhamsted. The High Street is therefore a crucial link and it is important that barriers are mitigated to provide conditions conducive to cycling.



Figures 1 – 3 Berkhamsted Town Centre – Existing Conditions

Footways have been built out and raised crossings with central islands provided to create a narrowing effect. Traffic humps with stone setts are located either side of the Kings Road Junction. Parking and loading areas are differentiated from the main carriageway with contrasting materials. While these measures may have successfully reduced traffic speeds, they have also served to create an increasingly difficult environment for cyclists.

Over time the condition of the paving and bond patterns has deteriorated, affecting not only the aesthetics of the High Street, but also severely impacting on the ride quality for cyclists through the town centre. This issue was raised frequently during Stage 1 consultation.

Overrun areas and textured surfacing can cause hazards for cyclists as highlighted in LTN 2/08 Cycle Infrastructure Design. This guidance emphasises that these areas should be avoided where the presence of cyclists is expected.



Figure 4 - 20mph Zone Berkhamsted High Street

Both horizontal and vertical traffic calming measures are in place in the High Street, with a 20mph zone extending from Three Close Lane to Boxwell Road (see **Figure 5** for details). Following discussions with local stakeholders, there is a perception that an extension to the current 20mph zone would enhance the town centre environment, but also improve the safety for vulnerable road users.

Since July 1999, the Road Traffic Regulation Act Order 1999 has given traffic authorities the powers to introduce both 20mph speed limits and 20mph zones without obtaining the consent of the Secretary of State, and that once introduced, successful 20mph zones and 20mph speed limits should be self-enforcing.

20mph speed limits are unlikely to be complied with on roads where vehicle speeds are substantially higher than this and, unless such limits are accompanied by the introduction of traffic calming measures. Police forces may find it difficult to routinely enforce the 20mph limit. Traffic authorities should therefore consult the local police force when considering possible 20mph limits or zones, and thereafter as part of the formal consultation process. In

addition, Hertfordshire County Councils Speed Management Strategy suggests that for a 20mph zone to be introduced, current speeds should not exceed the threshold of 25mph. Following a review of TrafficMaster data, it was found that there were areas adjacent to the existing 20mph zone that had 85<sup>th</sup> percentile speeds less than the threshold (see **Figure 8**).

For all measures proposed in the High Street, it is important to consider its multi-modal nature, ensuring that measures cater for all users including pedestrians, parking, servicing and the potential impact on trade.

The options have been developed to fulfil the following overarching LTP Objective:

- Improve transport opportunities for all and achieve behavioural change in mode choice;
- Enhance quality of life, health and the natural, built and historic environment for all residents
- Improve the safety and security of residents and other road users

Measures/Components			
Ref	Description	Assessment of Suitability	Cost
05.1	Investigate use of improved materials to enhance ride quality through High Street – replace cobbles with sawn granite / bound with resin	<p>Replace existing paved carriageway areas (notably at controlled and uncontrolled crossing points) with cycle friendly asphalt or clay paviours bound with a resin sealant. Care during construction and maintenance is crucial to provide a high quality finish with no hazardous joints or edges for cyclists (<b>Figure 7</b>). Existing raised areas should be replaced with sinusoidal humps in order to provide an improved finish for cyclists, with no upstand between the carriageway and hump level. These should comply with the requirements of the conservation area and offer a sufficient skid resistance.</p> <p>The pavement surface condition is also poor in a number of locations throughout the High Street.</p> <p>It is recommended that the use of improved materials and carriageway resurfacing are considered holistically as part of the routine maintenance programme, to minimise disruption and allow for efficiency savings.</p> <p>Deliverability - 1 to 2 years <b>STANDARD</b></p>	£140,000 to £150,000
05.2	ASLs at signals	As per proformas 01, 19 and 20, investigate the feasibility of implementing 4.0m Advanced Stop Lines (ASLs) on all approaches at the Kings Road Junction to increase priority for cyclists and	£6,000 to £8,000

		<p>improve conspicuity.</p> <p>Where possible, suitable feeder lanes should be provided, however width limitations mean it is likely ASLs would be gated.</p> <p>Deliverability - 1 to 2 years <b>STANDARD</b></p>	
05.3	<p>Implement cycle logos at strategic locations along the High Street to complement cycle route signage</p>	<p>Cycle logos to TSRGD diagram no. 1057 should be implemented at strategic locations along the High Street to encourage cyclists to adopt the primary position, reinforce the cycle route signage (refer to <b>Proforma 10</b>) and highlight the presence of cyclists to motorists. The following potential locations have been identified:</p> <ul style="list-style-type: none"> <li>• Adjacent to the parking bays eastbound at the commencement of the 20mph zone opposite Boxwell Road</li> <li>• At raised uncontrolled crossing points where central refuge islands are provided</li> <li>• On approach to Kings Road Junction prior to the flare eastbound and westbound</li> <li>• Upstream of the bus bay east of Kings Road Junction</li> </ul> <p>The requirements of Berkhamsted Conservation Area should be considered when progressing this option.</p> <p>Deliverability – less than 1 year <b>SIMPLE</b></p>	<p>£1,000 to £2,000</p>
05.4	<p>Extend the 20mph zone in Berkhamsted</p>	<p>20mph zones are predominantly used in urban areas, both town centres and residential areas – and in the vicinity of schools.<sup>1</sup> Berkhamsted High Street fits well with this description, with the location of adjacent residential areas and schools along its length.</p> <p>20mph zones are very effective at reducing collisions and injuries. This is confirmed in research that shows that the number of collisions involving injury to children may be reduced by up to two-thirds (Webster and Mackie, 1996).</p> <p>In relation to Berkhamsted High Street, 29 collisions occurred along the Durrants Lane to Swing Gate Lane section between 2007 and 2012 (demonstrated in <b>Figure 9</b>). Ten of these</p>	<p>£450,000 to £500,000</p>

<sup>1</sup> Extract from *DfT Circular 01/2006*, p18



		<p>collisions involved pedestrians with two involving cyclists. An extension to the 20mph zone should assist in the reduction in the number and severity of collisions, with the zone making conditions more conducive to cycling and improving the environment for non-motorised users.</p> <p>Following a review of TrafficMaster data for 2011, the 85<sup>th</sup> percentile speeds are less than 25mph for much of the High Street between Durrants Lane and Swing Gate Lane. It is therefore proposed to reduce the speed limit to 20mph along this section, in addition to side roads that fall within the same criteria (e.g. Lower Kings Road to Berkhamsted Station). <b>Figure 10</b> demonstrates the proposed extension.</p> <p>TrafficMaster data provides an average speed across a link, including congestion at junctions, thus providing only an insight into speed conditions on highway sections, without reflecting actual speeds that vehicles reach between junctions. As a result, further speed surveys would be required throughout the proposed 20mph zone extension in order to validate the TrafficMaster data and to fulfil the requirements for changes to speed limits.</p> <p>Deliverability – 1 to 2 years <b>STANDARD</b></p>	
05.5	Improve cycle parking in Berkhamsted High Street	Cycle Parking has been considered as part of <b>Proforma 14</b> .	
05.6	Redistribute carriageway to improve conditions for cyclists	<p>Identify opportunities to redistribute the carriageway to improve cycle provision:</p> <ul style="list-style-type: none"> <li>• Overrun area (0.9m wide) adjacent to traffic island east of Kings Road to be removed to create more carriageway space;</li> <li>• Narrow the central refuge islands to a minimum 1.5m (subject to investigation regarding footfall) to increase general traffic lane widths).</li> </ul> <p>Owing to the multi modal nature of the High Street and the high number of pedestrians, many with pushchairs, it is not deemed feasible to narrow the central refuges.</p>	



		Removal of the offside overrun areas may serve to increase speeds, and cyclists are expected to be on the nearside or in the primary riding position.  <b>NOT DELIVERABLE</b>	
<b>Supporting Evidence of Measures/Components</b>			
Refer to Figures 5 – 10.			



Tring, Northchurch and Berkhamsted UTP  
Scheme Proforma 05



12.7.4. Cycle Reservoir Depth

	Cycle reservoir depth
Recommended	4m generally, 5m where there are multiple approach lanes to be crossed.
Acceptable Limits	4m (Min), 5m (Max)
Absolute Limits	N/A

Table 4.12.7.1: Cycle reservoir depth

12.7.5. Feeder Lane Widths

	Feeder Lane Width
Recommended	1.5m
Acceptable Limits	1.2m
Absolute Limits	N/A

Table 4.12.7.2: Feeder lane width

Figure 6 – Extract from Road’s in Hertfordshire Design Guidance



Figure 7 – Example of well constructed carriageway blocks from Road’s in Hertfordshire Design Guidance



Tring, Northchurch and Berkhamsted UTP  
Scheme Proforma 05



**AECOM**





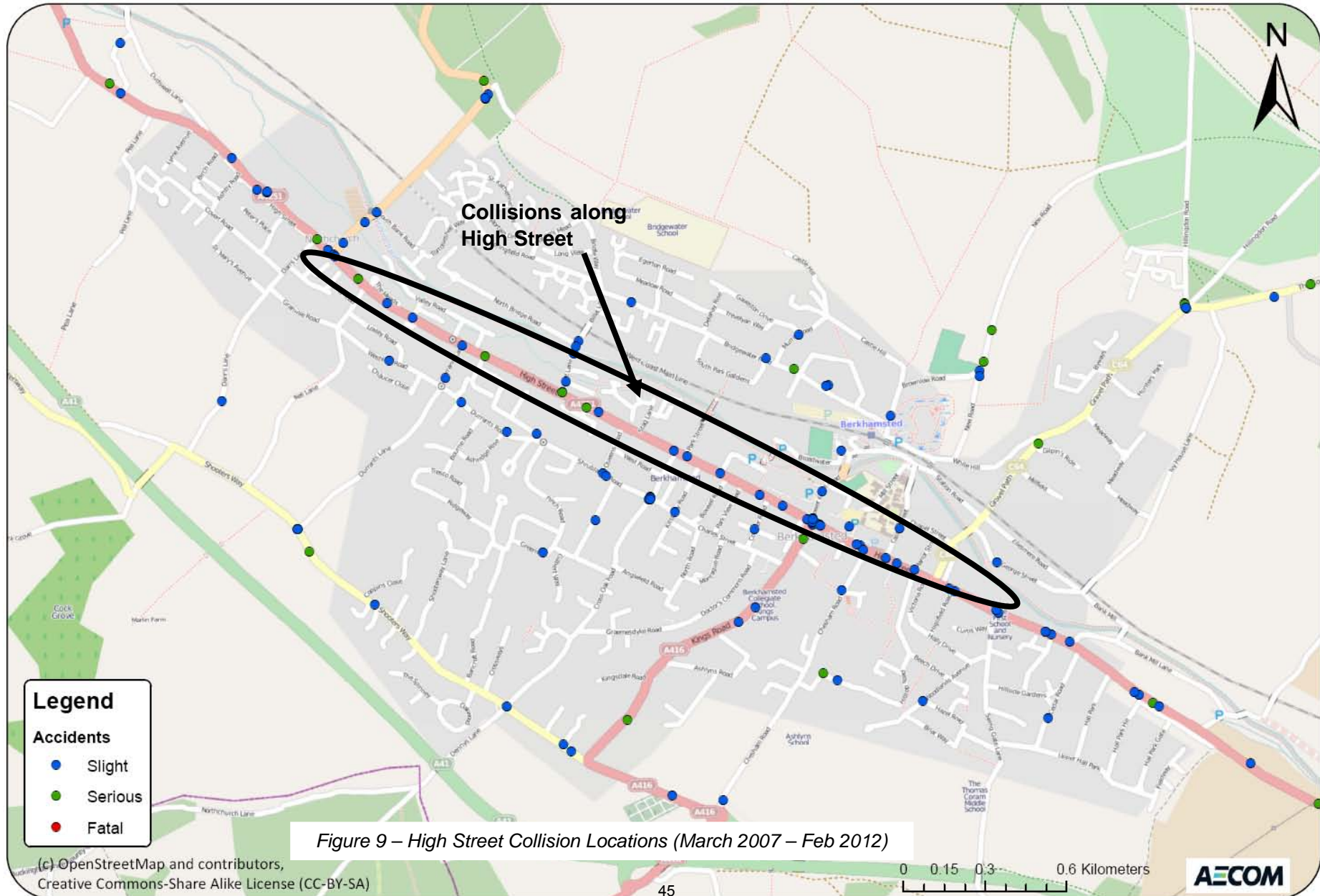



Tring, Northchurch and Berkhamsted UTP  
Scheme Proforma 05



**AECOM**

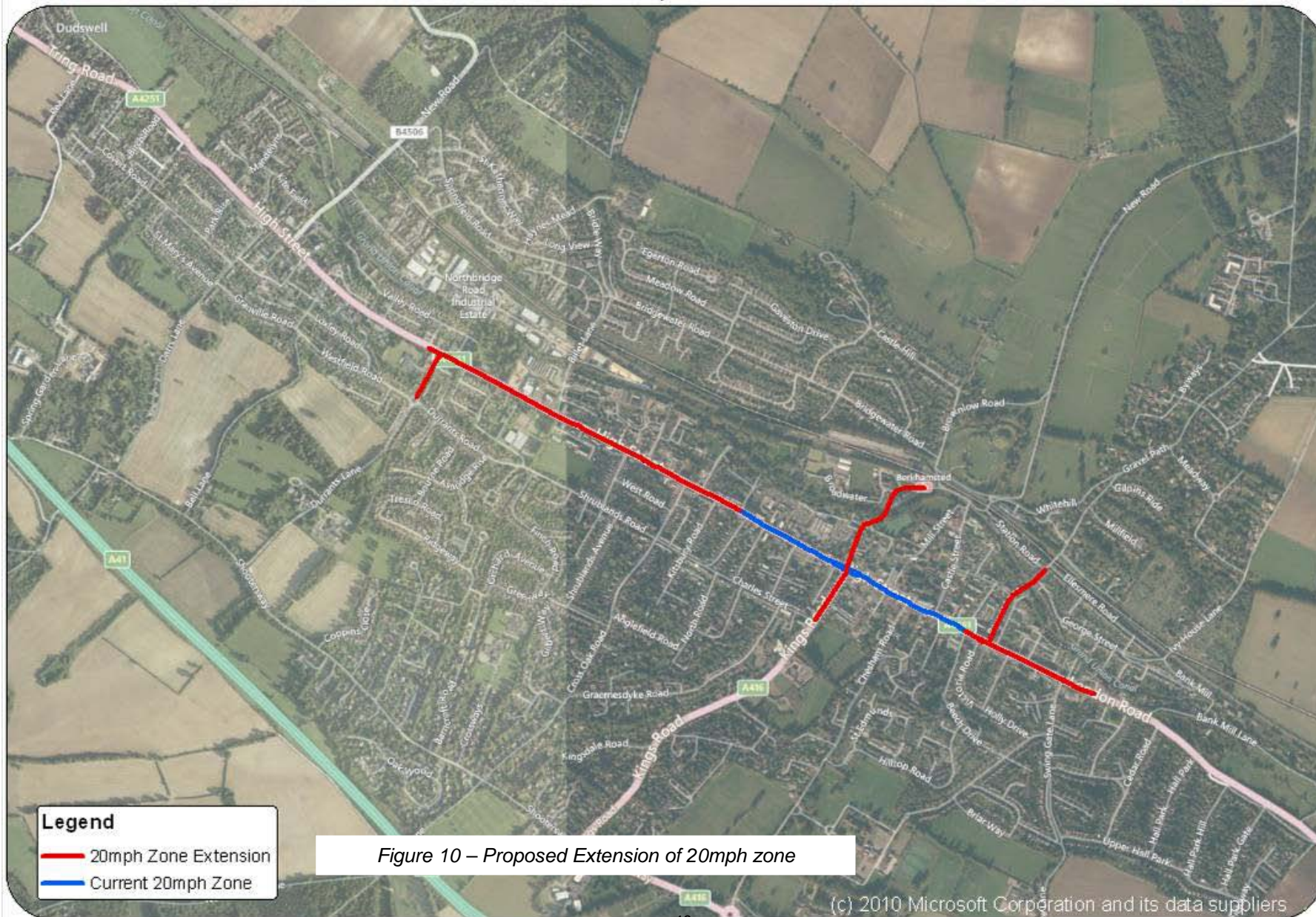



**Preferred Option**

It is recommended that 05.1, 05.3 and 05.4 are progressed, with an extension to the existing 20mph zone (subject to validation of speeds) and the provision of cycle friendly materials further investigated to ensure an environment conducive to cycling which serves to attract cyclists. The provision of ASLs (05.2) should be developed, following consideration of the impact on junction capacity at the three interchanges outlined.

These measures aim to improve conditions for Level 3 cyclists through this Bikeability Level 3 route.

<b>Contribution to Objectives / Indicators</b>	UTP Objectives	<ul style="list-style-type: none"> <li>Promote active travel modes throughout the study area to encourage active and healthy lifestyles;</li> <li>Reduce congestion in key traffic hotspots throughout the study area.</li> </ul>

**Outline Cost Analysis of Preferred Option or Options**

Design and Implementation	Indicative Cost*	Notes
05.1	£140,000 to £150,000	
05.2	£6,000 to £8,000	
05.3	£1,000 to £2,000	
05.4	£450,000 to £500,000	Based on requirement for at least 20 vertical features, including cost of street lighting, drainage, surfacing, white lining traffic management, drainage, advertising road hump notices, consultation, sign design and consultants design fees for letting the contract.
<b>TOTAL COST FOR DELIVERY</b>	<b>£597,000 to £660,000</b>	

<b>Maintenance Liability</b>	High Medium Low	05.3 will require ongoing maintenance
------------------------------	-----------------------	---------------------------------------

\*All costs provided by HCC

<b>Deliverability of Preferred Option</b>	Simple — 'quick win', could be delivered within 1 year
	<b>Standard – could be delivered in 1 to 2 years, in line with IWP</b>
	Complex — could not be delivered in 2 years, has some issues that require resolution before design



<b>Delivery Issues</b>	<p>The provision of improved facilities for cyclists must be balanced against the needs of pedestrians, general traffic and servicing in the High Street.</p> <p>Berkhamsted High Street falls within Berkhamsted Conservation Area.</p> <p>No requirement for land acquisition envisaged.</p> <p>Traffic Regulation Order required for implementation of 20mph zone.</p>
------------------------	---

**Other Information/Additional Notes:**

Existing highway dimensions are based on OS mapping provided by HCC and / or site measurements. It is recommended further survey work is carried out to provide a full assessment of available widths during feasibility design.

Dacorum Borough Council approval required for any changes in Berkhamsted town centre. Berkhamsted town centre is a conservation area and all proposals must be in line with Dacorum Borough Council objectives.

TrafficMaster Data has been provided via the Department for Transport (DfT) in order to complete an assessment of speeding at particular locations. In raw form, TrafficMaster data relates to satellite navigation journey times. Specifically for Tring and Berkhamsted, the data was available for the whole of 2011, providing sufficient journey time information for the assessment of all links across the local highway network. The journey time was translated into speed based on highway link length information, and then compared against ACPO thresholds (as seen below). TrafficMaster data provides an average speed across a link, including congestion at junctions, thus providing only an insight into speed conditions on highway sections, without reflecting actual speeds that vehicles reach between junctions. As a result, further speed surveys would be required to validate the TrafficMaster data and to fulfil the requirements for changes to speed limits.

<b>Scheme Name</b>	<b>Review Parking on Beggars Lane to Improve Safety for Cyclists</b> Highways and Congestion	
<b>Scheme Reference</b>	06	
<b>Problem References</b>	T15	Parking present on Beggars Lane for commuters using Tring Station - road is a cycle route and could cause conflicts
	PK11	Tring Station Car Park is full on weekdays
	PK13	Parking issues along Cow Lane
	PK16	Parking along country lanes to avoid station parking costs
<b>Links to other UTP schemes:</b>		

**Context**



*Figure 1 Location Plan*

Beggars Lane forms a connector road between Station Road in Tring and A4251 Tring Road. Located only 300m from the entrance to Tring Station, and with no parking restrictions along sections, Beggars Lane has become an overflow car park for the station, with many commuters taking advantage of the local free parking.

As a result, Beggars Lane can no longer accommodate both cyclists and car users due to significantly reduced carriageway width. In addition, safety has become a concern due to reduced visibility along the narrow lane.

In 2011, staggered parking restrictions were implemented along Station Road in order to improve road safety where visibility was poor. As a result, 30 unrestricted spaces were available throughout the day. However, there has recently been support for a full parking

restriction along Beggars Lane, as commuters continue to park between the current restrictions, and towards Newground Road. Thus, safety continues to be a problem for vulnerable road users.



Through a variety of transport schemes, the Urban Transport Plan will encourage a mode shift away from cars for commuters using Tring Station. This will involve the improvement of cycle infrastructure and public transport, but also reduce the attractiveness of using a private car to travel short distances. This scheme specifically looks into concerns regarding commuter parking along Beggars Lane, aiming to improve accessibility to the station for cyclists, in addition to improving the safety for road users. Interventions have been developed to fulfil the following overarching LTP Objectives:

- Improve transport opportunities for all and achieve behavioural change in mode choice
- Improve the safety and security of residents and other road users

Measures/Components			
Ref	Description	Assessment of Suitability	Cost
06.1	Increase parking restrictions (double yellow lines) along Beggars Lane to remove existing parking space for 30 vehicles	Concerns regarding commuter parking along Beggars Lane have been raised on a number of occasions since 2009. As a result, staggered parking restrictions were implemented in 2011 to restrict parking only where visibility is poor. Since 2011, there has been further support for restricted parking along the entire length. The proposed measure would improve the safety for road users along Beggars Lane as a result of improved visibility and road width, but also encourage commuter mode shift from the private car. The parking restrictions (double yellow lines) would extend from Station Road along Beggars Lane for 600m. Deliverability – 1 to 2 years <b>STANDARD</b>	£4,000 to £6,000
Supporting Evidence of Measures/Components			

Preferred Option	
The preferred option is to implement measure 06.1 along Beggars Lane. However, this measure should be implemented in parallel with improvements at Tring Station to ensure availability of parking for both cyclists and car drivers and to ensure that the pricing strategy is correct to maximum the spaces available at the station.	

Contribution to Objectives / Indicators	UTP Objectives	
		<ul style="list-style-type: none"> <li>Address parking issues regarding Tring and Berkhamsted Stations, through encouragement of car share schemes and mode shift from the car</li> </ul>

Outline Cost Analysis of Preferred Option or Options		
Design and Implementation	Indicative Cost	Notes
06.1	£4,000 to £6,000	
<b>TOTAL COST FOR DELIVERY</b>	<b>£4,000 to £6,000</b>	

Maintenance Liability	High Medium Low	

Deliverability of Preferred Option	<del>Simple – ‘quick win’, could be delivered within 1 year</del>
	<b>Standard – could be delivered in 1 to 2 years, in line with IWP</b>
	<del>Complex – could not be delivered in 2 years, has some issues that require resolution before design</del>
Delivery Issues	Delivery would require further consultation, which may take 1 or 2 years. Recent consultation has revealed mixed views on the removal of parking at this location.

Other Information/Additional Notes:



<b>Scheme Name</b>	<b>Tring Station Improvements</b> Cycling	
<b>Scheme Reference</b>	07	
<b>Problem References</b>	T06	Cycle parking is at, or close to, capacity at Tring Station and will require expansion in the future
	T16	Bridge by Tring Station - narrow and presents issues for cyclists
	T17	Signage / wayfinding from Tring Station to town is poor / confusing / incorrect. Link and signage to off carriageway facility needs improving.
	T19	Secure cycle parking at Tring Station is limited with limited CCTV coverage of cycle parking spaces
	T22	Lack of cycle parking at Tring Station
	PK11	Tring Station Car Park is full on weekdays
<b>Links to other UTP schemes:</b>	14, 12	

**Context**

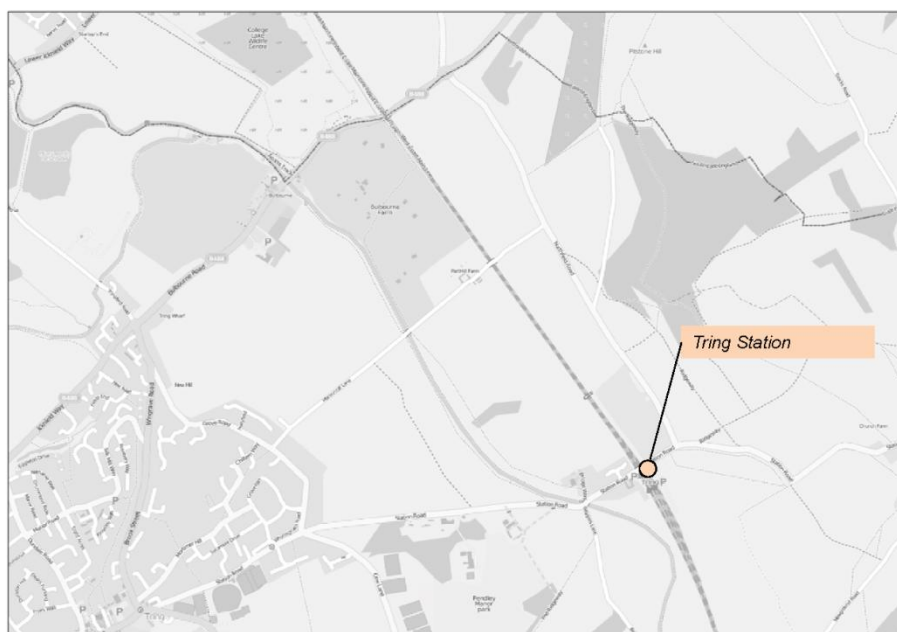

*Location Plan*

Tring Station is situated 2.5 kilometres to the east of Tring town centre and is operated by London Midland. The station is split into two areas to the east and west of the railway line. The western side has dedicated cycle parking with covered and uncovered cycle stands, with the eastern side providing vehicular parking with open and decked parking areas.

Owing to the distance from the town centre, it is vital that Tring Station adequately caters for cyclists. Cycle parking is currently at, or close to, capacity, with all cycle racks observed as being occupied during site visits. Due to the lack of spare capacity of the racks at the station, overspill parking occurs on the perimeter fencing surrounding the station. Additional cycle parking was implemented in 2011 - 2012 following HCC's Station Facility Review (2010), however, demand is still higher than the number of spaces available.

Car parking is located on the eastern side of the station with access to platforms directly from the car park. The car park has been observed as partially full (approximately 75%) during peak times, with spaces further away from the platform access less well used.

Cyclists arriving from the eastern side of the railway line currently have to continue over the railway bridge to access the station forecourt and cycle parking. The bridge is approximately 7.5m wide with a 1.5m footway on the northern side and a 0.3m footway on the southern side. This presents issues for cyclists travelling over the bridge as running lanes are 2.8m wide, with no provision for cyclists. The width allows cyclists to 'take the lane' adopting the primary position in the centre of the road. However, the presence of the walls can create an uncomfortable environment.



*Figure 1 – Existing cycle parking at Tring Station*

It is recognised that a review is required to establish bicycle friendly access points, some of which may not necessarily be at the existing points of entry.

As stated in LTN 2/08, Cycle Infrastructure Design, good quality cycle parking is a key element in developing a cycle friendly environment (chapter 11.1.1). The provision of improved infrastructure at Tring Station would meet the accessibility and convenience principles that underpin infrastructure design.



*Figure 2 – Tring Station Bridge from the west*

The options have been developed to fulfil the following overarching LTP Objectives:

- Improve transport opportunities for all and achieve behavioural change in mode choice;
- Enhance quality of life, health and the natural, built and historic environment for all residents
- Reduce transport's contribution to greenhouse gas emissions and improve its resilience

Measures/Components			
Ref	Description	Assessment of Suitability	Cost
07.1	Introduce extra cycle parking in existing locations and on eastern side of railway in the vehicle car park	<p>In coordination with London Midland, a number of locations have been identified where additional cycle parking can be provided or existing cycle parking upgraded:</p> <ul style="list-style-type: none"> <li>• Provide extra cycle spaces in the forecourt area by introducing a two-level bicycle parking system. The existing shelter has space for 40 cycles (<b>Figure 5</b>). There is vegetation behind the shelter that could be removed (<b>Figure 8</b>), with a new shelter relocated closer to the boundary wall and double decking provided with space for 80 cycles. This arrangement would allow for the existing cycle parking area to be shortened to allow for additional motorcycle parking, a key concern of Fog Cottage residents (<b>Figure 11</b>). <b>Figure 4</b> in the supporting evidence section shows a typical layout of two-tiered parking.</li> <li>• Provide additional cycle parking to the east of the railway line, immediately north of the decked car park and adjacent to the pedestrian walkway (<b>Figures 5 and 9</b>). This would involve the removal of two vehicle parking spaces to facilitate the provision of a two tiered cycle parking rack for 40 cycles with sufficient space to allow cyclists to access the existing pedestrian walkway. While this location is not directly adjacent to the station entrance, it is close enough to provide an attractive option for cyclists from the east without having to cross the road bridge. It is noted that provision of additional cycle parking will need to be balanced against the loss of car parking spaces and associated revenue. This facility should be appropriately signed.</li> </ul>	£30,000 to £40,000



		<p>Proposals are in place to provide additional cycle parking in 2013, utilising funding from DfT's Cycle Rail Fund. Twelve cycle spaces with shelter are currently proposed to the west of railway line adjacent to the forecourt entrance (<b>Figure 5</b>).</p> <p>In the future there are also potential opportunities to utilise the space behind the existing taxi office, on the 'old bridge' for further parking for 20 cycles (<b>Figure 10</b>). This area is already paved, and would require vegetation removal and a dropped kerb access in order to facilitate parking here.</p> <p>This would increase the existing cycle parking provision from 125 from 237 if all cycle parking proposals were to be implemented.</p> <p>To fully promote and encourage cycling for short journeys, cycle parking at the station should be clearly signed. Signs should be provided to TSRGD 2603 and 2604 as required.</p> <div style="text-align: center;">  </div> <p>Deliverability- Less than 1 year <b>SIMPLE</b></p>	
--	--	---	--

07.2	Improved security of existing cycle parking	<p>Secure cycle parking at origins and destinations enhances cycling infrastructure and promotes trips. The provision of secure cycle parking is a key objective of Hertfordshire County Council's cycling strategy (HCS6).</p> <p>The proposal at Tring station includes the provision of CCTV cameras to monitor all cycle parking and a review of lighting to ensure the areas of parking are lit to a comfortable standard.</p> <p>Posters could be used to support the security of the cycle parking. A successful campaign has been used at Newcastle University, as shown in <b>Figure 3</b>. Research has shown that posters of eyes have a psychological effect in deterring crime.</p>  <p><i>Figure 3 – Example of deterrent poster</i></p> <p>Deliverability- Less than 1 year <b>SIMPLE</b></p>	£15,000 to £20,000
07.3	Sign cyclists through the station subject to bridge width / parapet height / NR permissions	<p>The bridge across the railway lines is narrow and creates a difficult environment for cyclists and vulnerable road users. It may be possible to utilise the existing footbridge within the station as a potential alternative alignment (<b>Figure 7</b>). This structure could cater for cyclists on foot but it would not be advisable to allow cycling on the bridge due to narrow width, high footfall at peak times and parapet height. Signing would be an appropriate measure to enable cyclists to utilise the bridge, and would be subject to London</p>	



		Midland agreement.  <b>NOT DELIVERABLE</b>	
07.4	Improve conditions for cyclists across Station Road bridge	<p>The provision of cycle signing and markings (cycle logos to TSRGD Diag. No. 1057 and signs to TSRGD Diag. No. 950) on Station Road at the bridge (<b>Figures 5 and 6</b>) would improve the conspicuity of cyclists without any major civil works.</p> <p>This would assist in the provision of an improved cycle link to Pitstone Village as outlined in Scheme Proforma 12.</p> <p>Deliverability – 1 to 2 years <b>STANDARD</b></p>	£2,000 to £4,000
07.5	Link to Pitstone Village	Link to Pitstone has been considered as part of <b>Scheme Proforma 12</b> .	

**Supporting Evidence of Measures/Components**

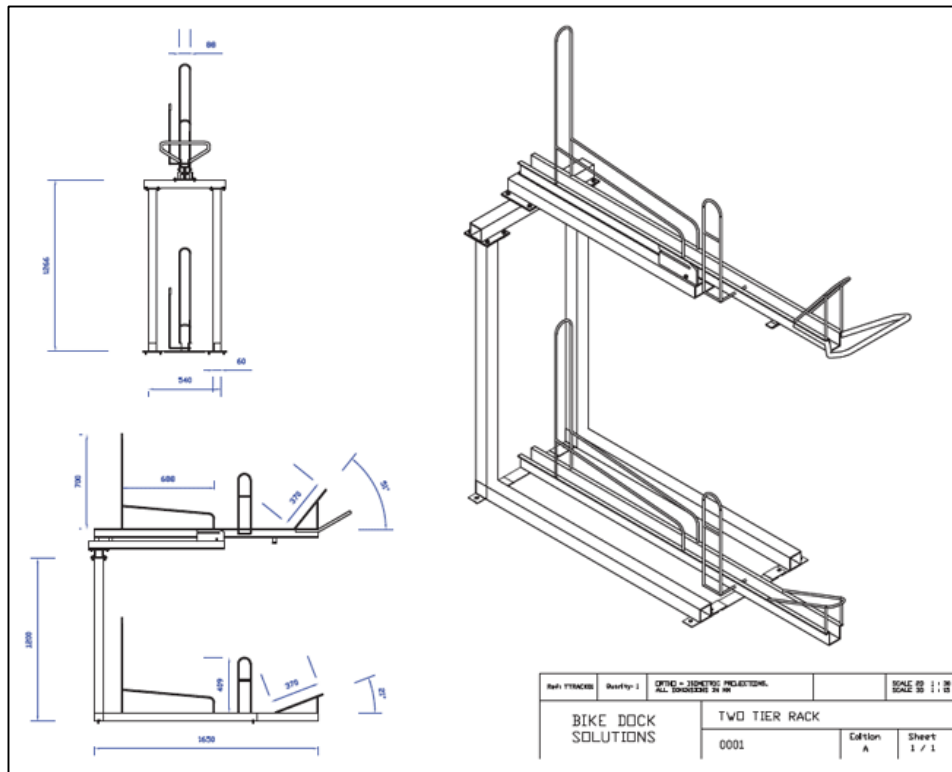

Figure 4 – Two Tier cycle parking example



# Tring, Northchurch and Berkhamsted UTP Scheme Proforma 07



Last saved by: GARRICKHC(2013-04-30) Last Plotted: 2013-05-01  
 Filename: F:\PROJECTS\TRAFFIC - HCC\BIKEABILITY AUDIT - TRING AND BERKHAMSTED\11\_CAD\PROFORMA EXCERPTS\CY2 - TRING STATION.DWG

Project Management Initials: Designer: MJA Checked: HCG Approved: ADR ISO A4 210mm x 297mm

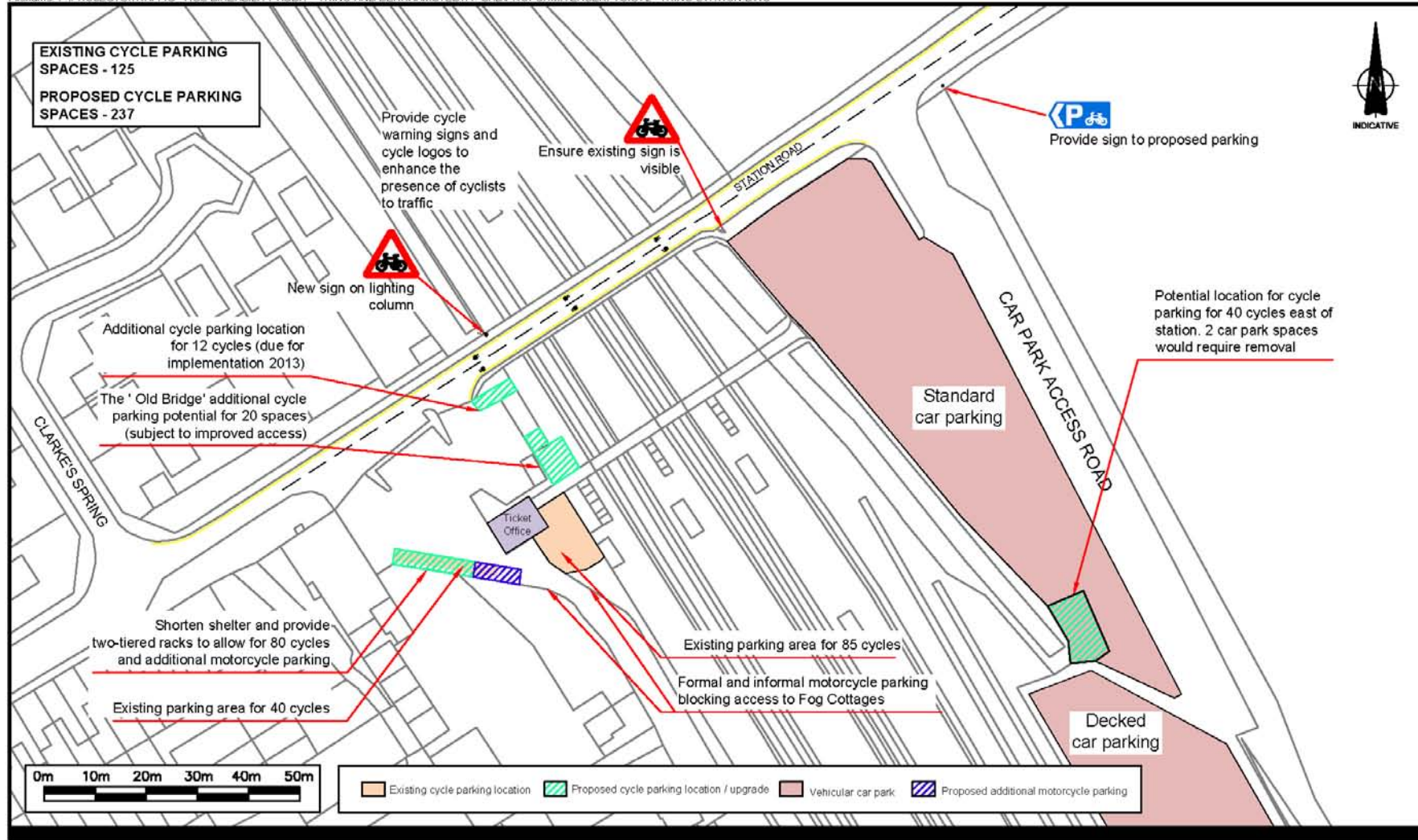

**Tring and Berkhamsted  
 Urban Transport Plan**  
 Hertfordshire County Council  
 Project No.: 60267074 Date: April 2013



**Figure 5 - Tring Station Proposals**



*Figure 6 – Station Road Bridge*



*Figure 7 – Station Footbridge*



*Figure 8 – Vegetation behind existing cycle shelter to be removed to provide two-tiered rack*





*Figure 9 – Potential cycle parking location to east of the railway line with removal of 2 parking bays*



*Figure 10 – ‘Old Bridge’ potential area for future cycle parking*



*Figure 11 – Motorcycles regularly block access to Fog Cottages*



**Preferred Option**

Options 07.1, 07.2 and 07.4 are recommended to be advanced to ensure that infrastructure is implemented in line with demand. The provision of improved parking facilities and security may encourage further growth of cycle trips to the station, meeting key LTP objectives.

The combination of measures will highlight the facilities for cyclists at the station and enable cyclists to traverse the railway in a more comfortable and convenient cycling environment.

Option 07.3 is perceived to be undeliverable due to infrastructure issues and conflict between users.

<p><b>Contribution to Objectives / Indicators</b></p>	<p>UTP Objectives</p>	<ul style="list-style-type: none"> <li>• Improve connectivity between transport modes to allow for greater transport flexibility;</li> <li>• Improve public transport provision and accessibility;</li> <li>• Promote active travel modes throughout the study area to encourage active and healthy lifestyles.</li> </ul>
---	-----------------------	--



<b>Outline Cost Analysis of Preferred Option or Options</b>		
<b>Design and Implementation</b>	<b>Indicative Cost*</b>	<b>Notes</b>
07.1	£35,000 to £40,000	
07.2	£15,000 to £20,000	
07.4	£2,000 to £4,000	
<b>TOTAL COST FOR DELIVERY</b>	<b>£52,000 to £64,000</b>	

\*Costs provided by HCC

<b>Maintenance Liability</b>	High Medium Low	On-going cost of CCTV provision and additional lighting
------------------------------	-----------------------	---

<b>Deliverability of Preferred Option</b>	<del>Simple — ‘quick win’, could be delivered within 1 year</del>
	<b>Standard – could be delivered in 1 to 2 years, in line with IWP</b>
	<del>Complex — could not be delivered in 2 years, has some issues that require resolution before design</del>
<b>Delivery Issues</b>	London Midland approval sought for works on their land.

Other Information/Additional Notes:

Existing highway dimensions are based on OS mapping provided by HCC and / or site measurements. It is recommended further survey work is carried out to provide a full assessment of available widths during feasibility design.